

**WARNING:** Do not dispose of Ni-Mh batteries in the regular trash, municipal waste stream or by fire as batteries may leak or explode. Do not open, short circuit or mutilate batteries as injury may occur. Preserve our environment by recycling Ni-Mh batteries or disposing of them in accordance with local, State and federal regulations. Do not mix old and new batteries. Do not mix Alkaline, Standard (Carbon-Zinc) or rechargeable (Nickel Cadmium) batteries.

### Maintenance

Clean the solar module regularly with a damp towel to guarantee optimum performance of the solar panel. Do not use any type of solvent for cleaning and be careful not to put too much pressure on the module while cleaning.

### Trouble Shooting

If your solar charged light does not come on at dusk despite observance of all the instructions, please try the following steps:

1. Make sure that the solar light is not being affected by any other light source.
2. Make sure the switch is in "On" Position near the edge of the head lamp unit.
3. Ensure the solar light is not positioned in the shade during the day.
4. Check that the batteries are installed correctly.

**NOTE:** The performance of the solar light will vary with the time of the year. It will deliver more light when it has had a full day in the sun rather than a day in overcast weather.

**WINTERTIME TIPS:** Keep snow and debris cleaned off the solar panels so the batteries can recharge. If the lights are covered with snow for an extended period of time, after the snow melts, allow all the batteries to charge in full, direct sunlight for at least 6 hours to their maximum capacity.

**WARNING:** Please keep out of reach of children.

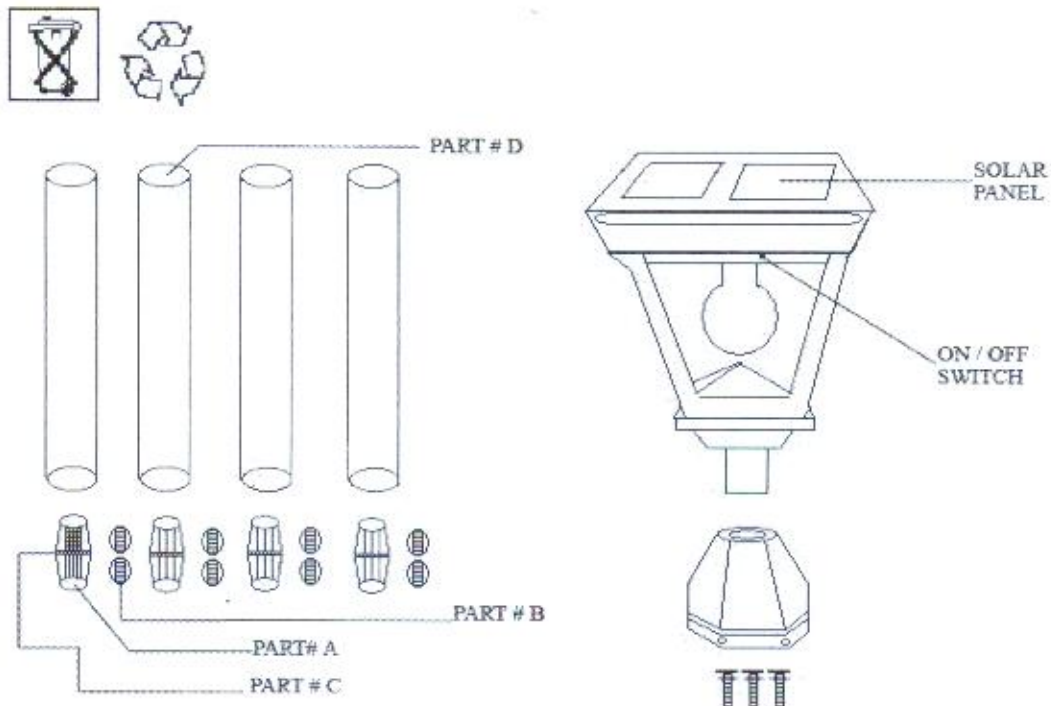

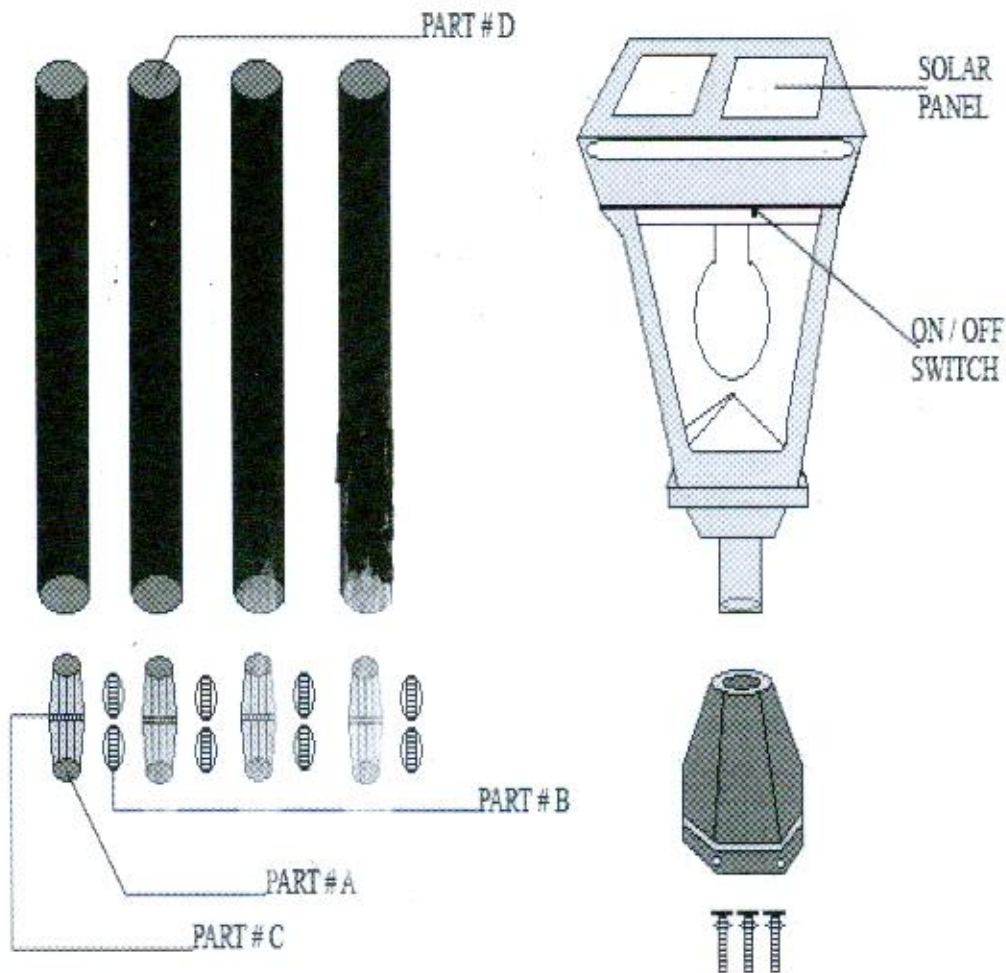

### Replacing the Batteries

(After several years of use, the batteries may need to be replace)

1. Detach the top of the lamp unit by releasing the 4 screws that is mounted around the edges of the head lamp unit by releasing the 4 screws and twisting it counter-clockwise and slowly lift up the cover of the head lamp.
2. Make sure the selector switch is in "OFF" position.
3. Please remove 2 additional screws that is covering the battery holder, inside the battery holder you will find a total of three (3) 1000mAh Ni-MH AA batteries.
4. Make sure the new batteries are high quality Ni-Mh AA rechargeable pack batteries with the same 1000mAh Ni-MH batteries if you change you must use all 3 new batteries does not mix and match with the old batteries.
5. Once the batteries is replace, be careful installing the cover back into the head lamp, make sure the cover that have the "On/OFF" switch is on the same side line together before assemble the screws.
6. Reassemble the unit by reversing the above procedure.

**WARNING:** Do not dispose of Ni-Mh batteries in the regular trash, municipal waste stream or by fire as batteries may leak or explode. Do not open, short circuit or mutilate batteries as injury may occur. Preserve our environment by recycling Ni-Mh batteries or disposing of them in accordance with local, State and federal regulations. Do not mix old and new batteries. Do not mix Alkaline, Standard (Carbon-Zinc) or rechargeable (Nickel Cadmium) batteries.

### Maintenance

Clean the solar module regularly with a damp towel to guarantee optimum performance of the solar panel. Do not use any type of solvent for cleaning and be careful not to put too much pressure on the module while cleaning.

### Trouble Shooting

If your solar charged light does not come on at dusk despite observance of all the instructions, please try the following steps:

1. Make sure that the solar light is not being affected by any other light source.
2. Make sure the switch is in "On" Position near the edge of the head lamp unit.
3. Ensure the solar light is not positioned in the shade during the day.
4. Check that the batteries are installed correctly.

**NOTE:** The performance of the solar light will vary with the time of the year. It will deliver more light when it has had a full day in the sun rather than a day in overcast weather.

**WINTERTIME TIPS:** Keep snow and debris cleaned off the solar panels so the batteries can recharge. If the lights are covered with snow for an extended period of time, after the snow melts, allow all the batteries to charge in full, direct sunlight for at least 6 hours to their maximum capacity.

**WARNING:** Please keep out of reach of children.

